

SPECIFICATION FOR APPROVAL

规 格 书

Customer (客户): _____

Customer part No: _____
(客户型号)

Our part No : JMS3254IB-02R-8□1W
(本厂型号)

Date (日期) : 2011-10-05

Environment Request: (环境标准)

NON-ROHS (非 ROHS 标准) ROHS (ROHS 标准)

OTHERS (其它) : _____

CUSTOMER'S APPROVED SIGNATURE



常州市杰之美电声器材有限公司 CHANGZHOU JIEZHIMEI ELECTRONICS INC.

Address: Bei Miao Qiao Village, Ming Huang Town, Changzhou City, Jiangsu, P.R.China
213164

Tel: +86-519-8129 8007

Fax: +86-519-8129 9007

Http://www.jm-speaker.com

E-mail: jiezhimei@188.com

	DESIGNED	CHECKED	APPROVED
SIGNATURE	Dejun Zang	Wendy Yan	Samsoon Duan
DATE	2011-10-05	2011-10-05	2011-10-05

Preliminary version for reference only

变 更 历 史

Note 序号	Date 日期	Detail changes 变 更 内 容	Reason 变更理由	Revision 变更表示

Loud Speaker Specification

Part No.	Customer No 顾客型号		Customer code 顾客编号	
	Our Part No 本厂编号	JMS3254IB-02R-8□1W		Revision 版本 V00
No.	Item 项目	Specification 规格	Testing Condition 测试条件	
1.	Rated Imp 共称阻抗	8 ohm \pm 15%	At 1 kHz 1.0 Vrms	
2.	Resonance Freq 最低共振周波数	750 Hz \pm 20%	Without Baffle	
3.	Output S.P.L. 出力音压	94 \pm 3 dB	At 0.1m 0.1W 800, 1k, 1.2k, 1.5KHz Average	
4.	Rated Power 定格入力	at 1.0 W	at 2.83 Vrms	
5.	Max Power 最大入力	at 1.5 W	at 3.46 Vrms	
6.	Frequency Range 实效频宽	F0----6 kHz	Output S.P.L. -10dB	
7.	Operation 可靠性试验	Must Be Normal	Program Source 1.0 W	
8.	Buzzes & Rattles 异常音试验	Should not be audible buzz and rattle 无异常声	Sine Wave Between (正弦波入力) at 2.83 Vrms / F0----6 kHz	
9.	Distortion 失真	5% Max	Rated Power Input 1000Hz	
10.	Magnet 磁铁	Size: Φ 12.5*1.5 mm N35 Flux Density: ----- Gauss(高斯)		
11.	Operating Temperature 工作温度	-20°C to +60°C		
12.	Storage Temperature 储存温度	-30°C to +60°C		
13.	Weight 重量	7.2 g/PCS		

Our P/N: JMS3254IB-02R-8□1W

14.	Cold Test 耐寒试验	After having been in a test chamber for 96 hours at the condition of $-20^{\circ}\text{C} \pm 2^{\circ}\text{C}$ and then left 2 hours in a room. ($-20^{\circ}\text{C} \pm 2^{\circ}\text{C}$, 96 小时试验室温两小时后, 无异常)
15.	Heat Test 耐热试验	After having been in a test chamber for 96 hours at the condition of $+60^{\circ}\text{C} \pm 2^{\circ}\text{C}$ 90~95% R.H and then left 2 hours in a room. ($+60^{\circ}\text{C} \pm 2^{\circ}\text{C}$ 90~95% R.H 96 小时试验常温 2 小时后, 无异常的不良)
16.	Load Test 连续负荷试验	Must be normal after load test :white noise 1.0 W 96 hours. (白噪音 1.0 W 连续 96 小时试验后无异常的不良)
17	Short Term Maximum Power test 瞬间最大功率测试	Test for 1 hour under maximum power. Input shall be white noise in rated frequency response. And the signal will be 1 second on, 59 seconds off, total 60 cycles. (白噪音 1.5 W, 1 秒开 59 秒关, 连续 60 循环, 试验后无异常之不良)
18.	Polarity 极性	When a positive D.C current is applied to the voice terminal marked + or white, the diaphragm shall move forward (端子的正极输入电流, 振动板向前方向运动)
19.	Drop Test 跌落试验	Drop the speakers contained in normal box onto a board 5mm thick 10 times from a height of 1.0m . (在厚 5mm 的木板上从 1.0m 的高度跌落 10 次, 无异常不良)
20.	Terminal strength 端子强度	A static load of 5.0N shall be applied to the terminals for 10s in any direction between terminal block and frame and between terminal block and fasten terminal. (端子板和支架或焊片任一方向上 5.0N 的力 10s 无异常)

Temperature Cycle Test(5 cycle)

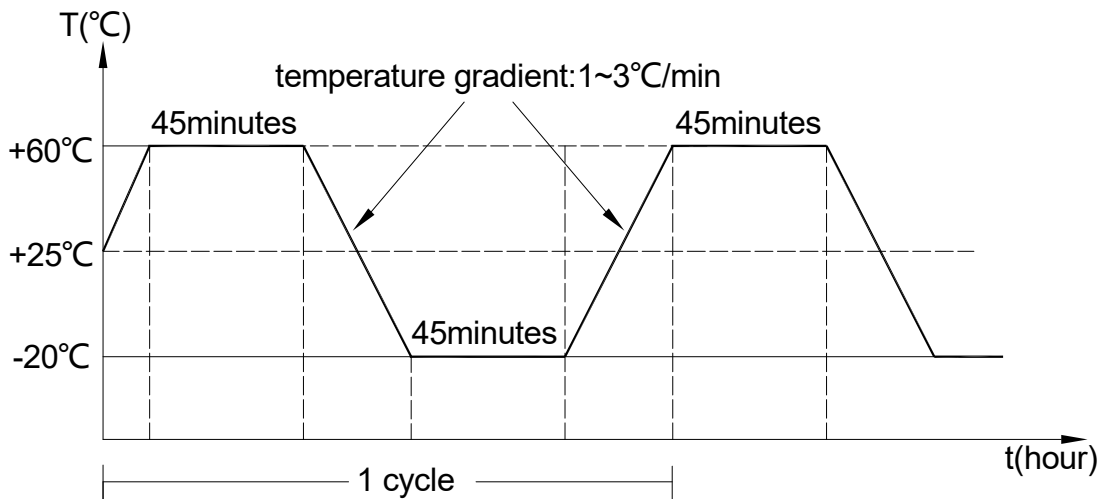

Our P/N: JMS3254IB-02R-8□1W

Frequency Response

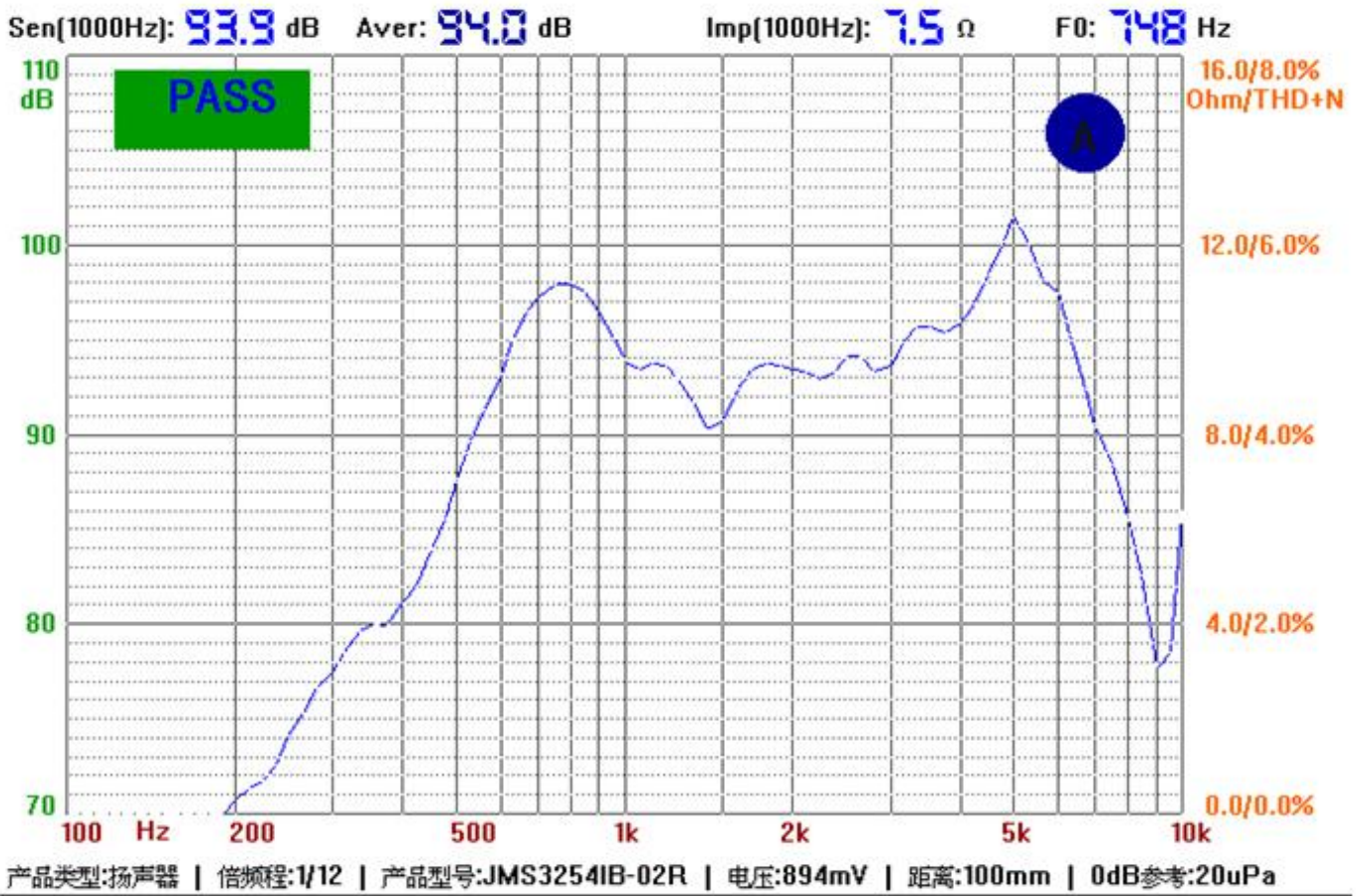

MEASUREMENT CIRCUIT

Standard test condition of speaker

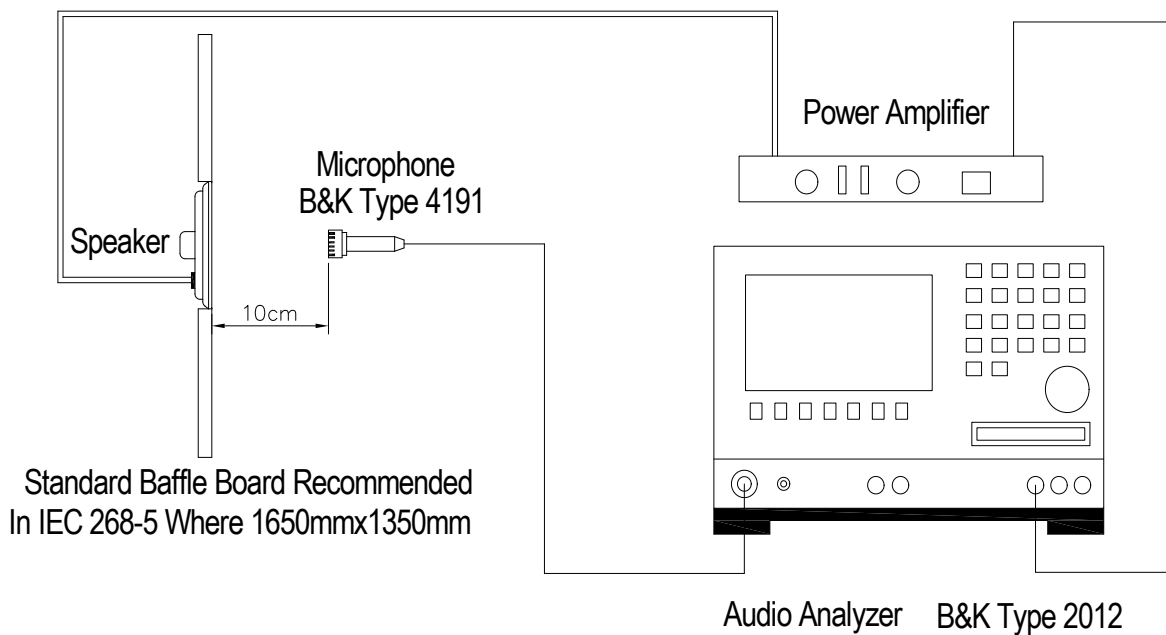

Our P/N: JMS3254IB-02R-8□1W

Product Outside View

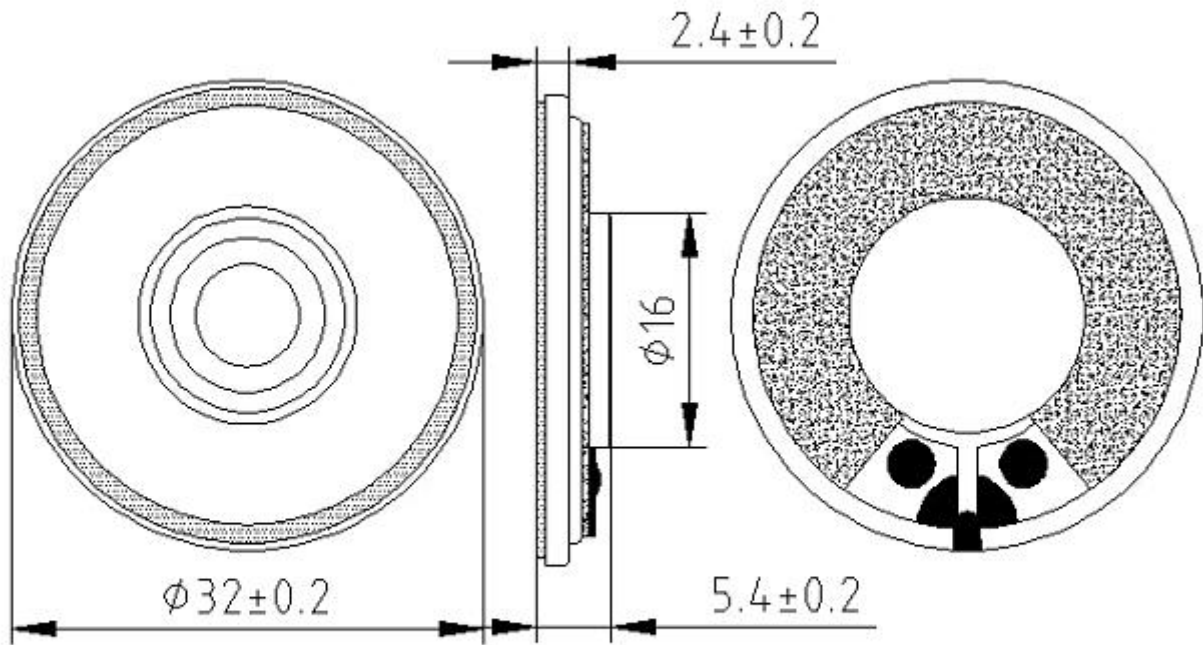

NOTE:

Unit: mm

Noise Testing

Testing Method 测试方法	
Item 步骤	Testing Condition 测试条件
1. Testing voltage 测试电压	2.83 Vrms
2. Testing Frequency Range 测试频率范围	From F0 to 6 kHz
3. Testing speed 扫描速度	$S \geq 0.8s/Cycle$
4. Operation 测试方法	The distance from speaker to tester's ear is 30cm 距离测试者耳朵 30cm 处监听,声音清纯无异常音为 OK

Our P/N: JMS3254IB-02R-8□1W

Packing View

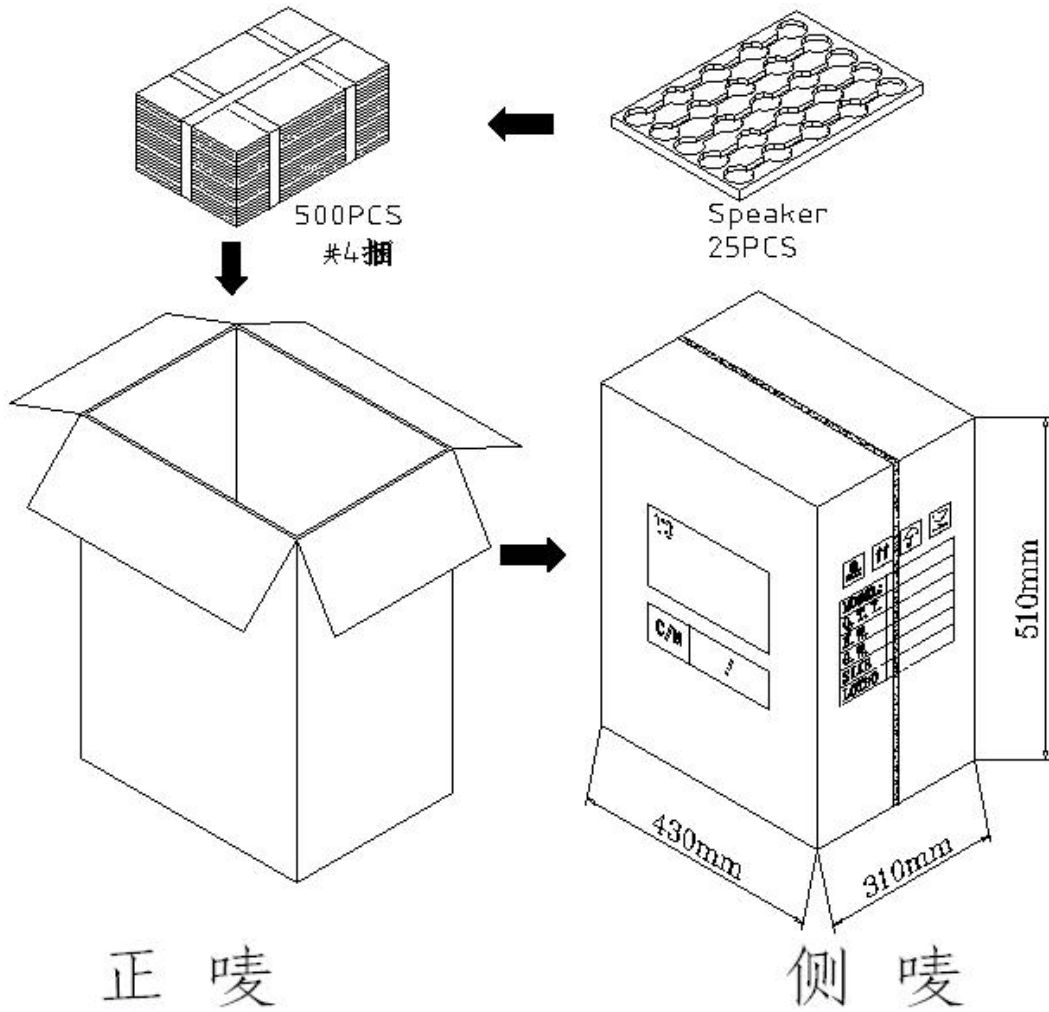

T0	
----	--

C/N	/
-----	---



MODEL:	
Q. T. Y.	
N. W.	
G. W.	
SIZE	
LOTNO	

NOTE:
2000PCS/BOX