

SPECIFICATION FOR APPROVAL

规 格 书

Customer (客户): _____

Customer part No: _____
(客户型号)

Our part No : JMS3050IW-50RL-4Ω3W
(本厂型号)

Sample No : _____
(样品编号)

Date (日期) : 2018-09-17

Environment Request: (环境标准)

NON-ROHS (非 ROHS 标准) ROHS (ROHS 标准)

OTHERS (其它) : _____

CUSTOMER'S APPROVED SIGNATURE



常州市杰之美电声器材有限公司

CHANGZHOU JIEZHIMEI ELECTROACOUSTIC EQUIPMENT CO., LTD.

Adds: 常州市武进区坂上工业区殷家塘 35 号

Tel: +86-519-8129 8007

Fax: +86-519-8129 9007

[Http://www.jm-speaker.com](http://www.jm-speaker.com)

E-mail: dmzhang@jm-speaker.com

	DESIGNED	CHECKED	APPROVED
SIGNATURE	Yliang	Yliang	Samsoon Duan

Preliminary version for reference only

变更历史

Note 序号	Date 日期	Detail changes 变更内容	Reason 变更理由	Revision 变更表示

Loud Speaker Specification

No.	Item 项目	Specification 规格	Testing Condition 测试条件
1.	Rated Imp 共称阻抗	4 Ω ± 15%	At 1 kHz 1.0 Vrms
2.	Resonance Freq 最低共振周波数	850Hz ± 20%	Without Baffle
3.	Output S.P.L. 出力音压	94 ± 3dB	At 0.1m 0.1W 800,1K,1.2K,1.5KHz Average
4.	Rated Power 定格入力	3.0 W	
5.	Max Power 最大入力	3.5 W	
6.	Frequency Range 实效频宽	F0----10K Hz	Output S.P.L. -10dB
7.	Operation 可靠性试验	Must Be Normal	Program Source Rated Power
8.	Buzzes & Rattles 异常音试验	Should not be audible buzz and rattle 无异常声	Sine Wave Between (正弦波入力) at 3.46Vrms / F0----10KHz
9.	Distortion 失真	10% Max	0.1W Input 1000Hz
10.	Magnet 磁铁	Size: Φ12.5*1.5mm N38 Flux Density: ----- Gauss(高斯)	
11.	Operating Temperature 工作温度	-10°C to +60°C	
12.	Storage Temperature 储存温度	-30°C to +70°C	
13.	Weight 重量	~g/PCS	

14.	Cold Test 耐寒试验	After having been in a test chamber for 96 hours at the condition of $-30^{\circ}\text{C}\sim 2^{\circ}\text{C}$ and then left 2 hours in a room. ($-30^{\circ}\text{C}\sim 2^{\circ}\text{C}$, 96 小时试验室温两小时后, 无异常)
15.	Heat Test 耐热试验	After having been in a test chamber for 96 hours at the condition of $+70^{\circ}\text{C}\sim 2^{\circ}\text{C}$ 90~95% R.H and then left 2 hours in a room. ($+70^{\circ}\text{C}\sim 2^{\circ}\text{C}$ 90~95% R.H 96 小时试验常温 2 小时后, 无异常的不良)
16.	Load Test 连续负荷试验	Must be normal after load test :white noise Rated Power 96 hours. (白噪音定格入力连续 96 小时试验后无异常的不良)
17	Short Term Maximum Power test 瞬间最大功率测试	Test for 1 hour under maximum power. Input shall be white noise in rated frequency response. And the signal will be 1 second on, 59 seconds off, total 60 cycles. (白噪音最大入力, 1 秒开 59 秒关, 连续 60 循环, 试验后无异常之不良)
18.	Polarity 极性	When a positive D.C current is applied to the voice terminal marked + or white, the diaphragm shall move forward (端子的正极输入电流, 振动板向前方向运动)
19.	Drop Test 跌落试验	Drop the speakers contained in normal box onto a board 5mm thick 10 times from a height of 1.0m . (在厚 5mm 的木板上从 1.0m 的高度跌落 10 次, 无异常不良)
20.	Terminal strength 端子强度	A static load of 5.0N shall be applied to the terminals for 10s in any direction between terminal block and frame and between terminal block and fasten terminal. (端子板和支架或焊片任一方向上 5.0N 的力 10s 无异常)

Temperature Cycle Test(5 cycle)

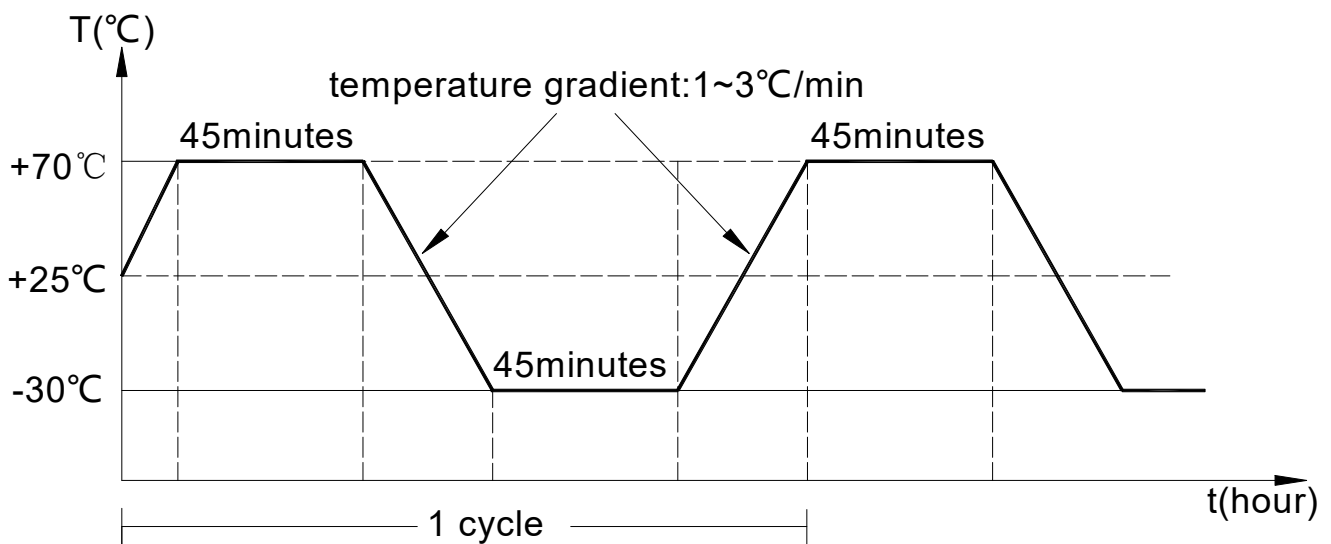

Frequency Response

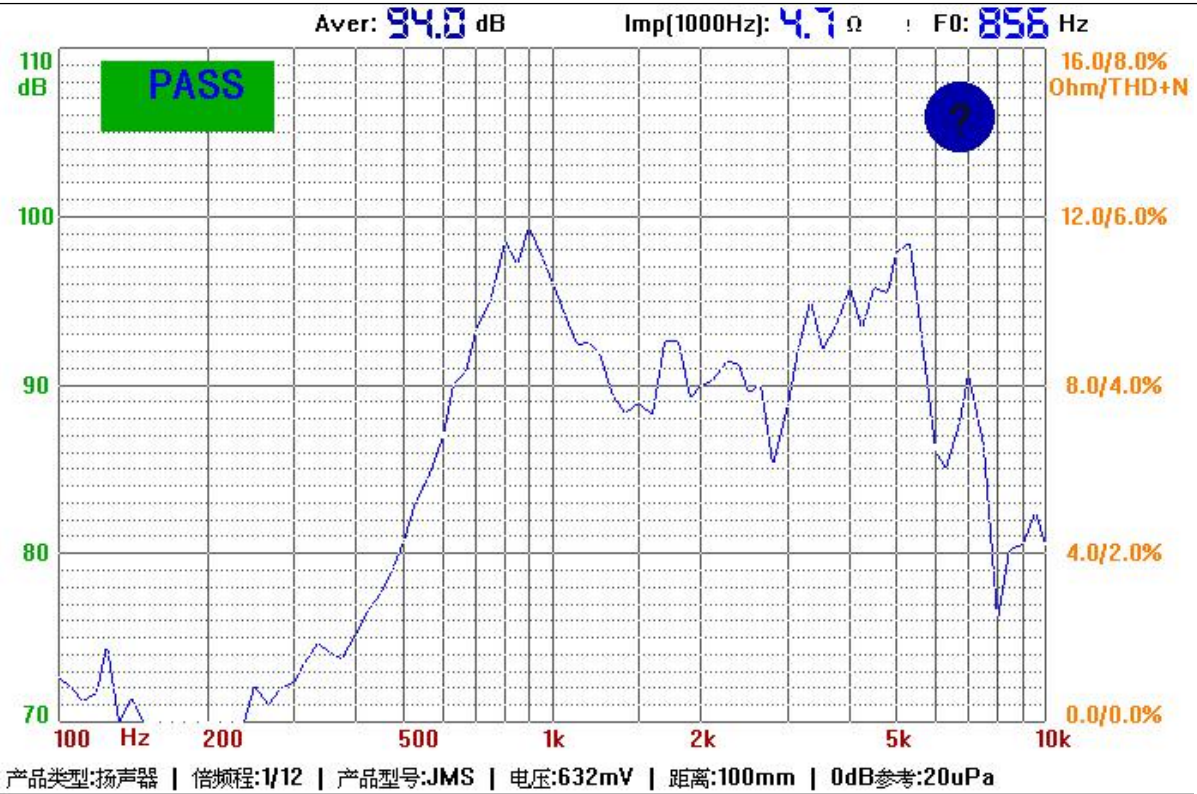

MEASUREMENT CIRCUIT

Standard test condition of speaker

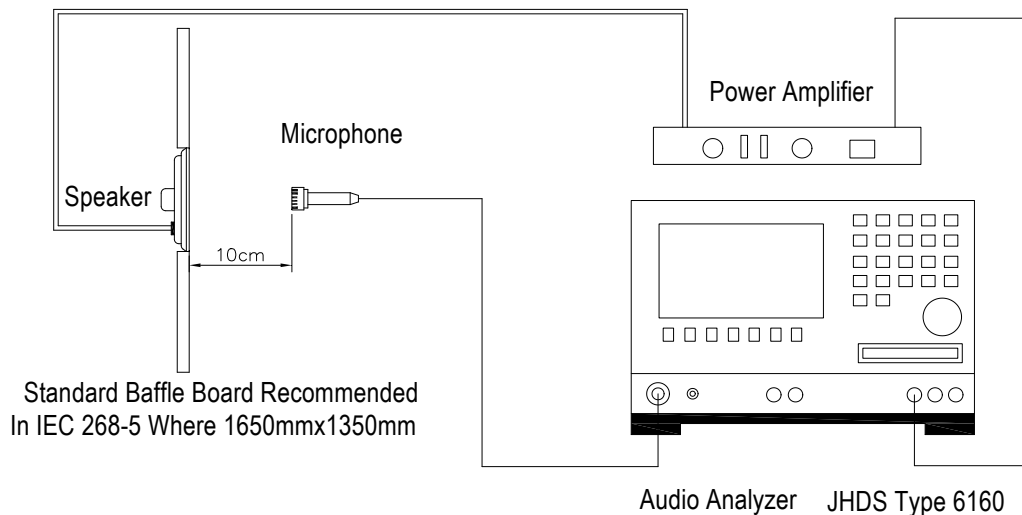

Product Outside View

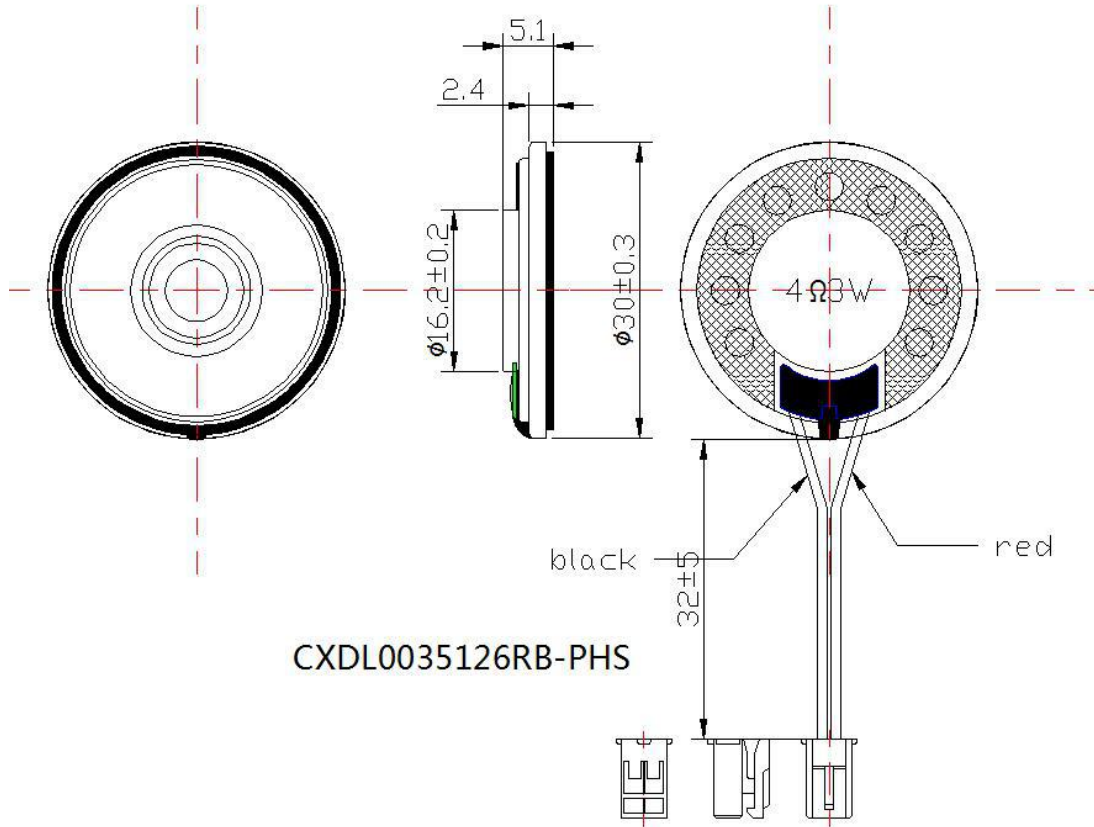

Unnoted tolerances: ± 0.3

Unit: mm

Product Photos 产品照片

Back
背面

Positive
正面

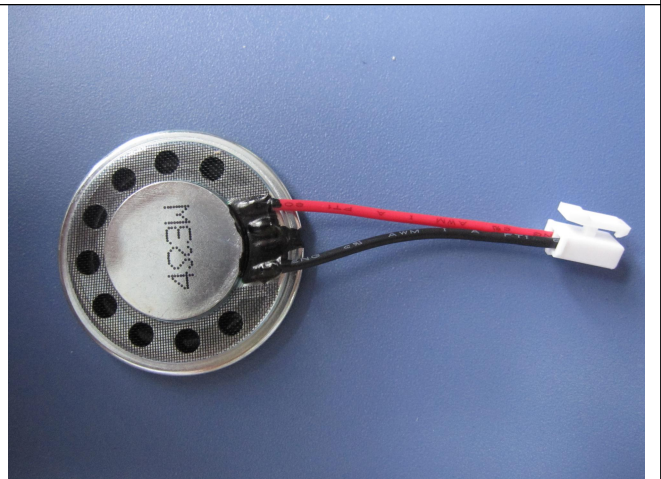
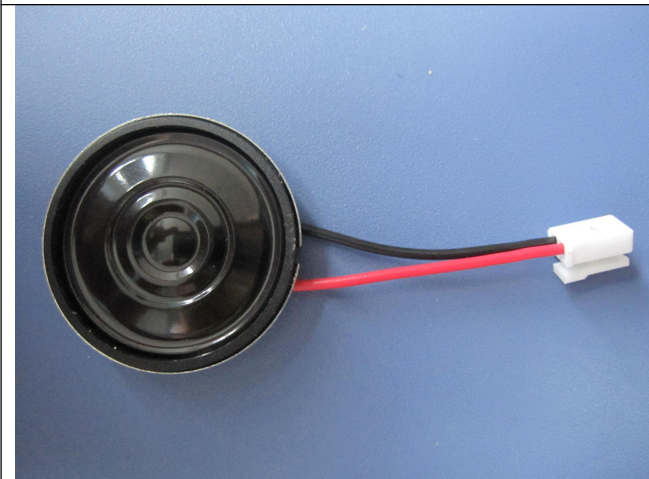

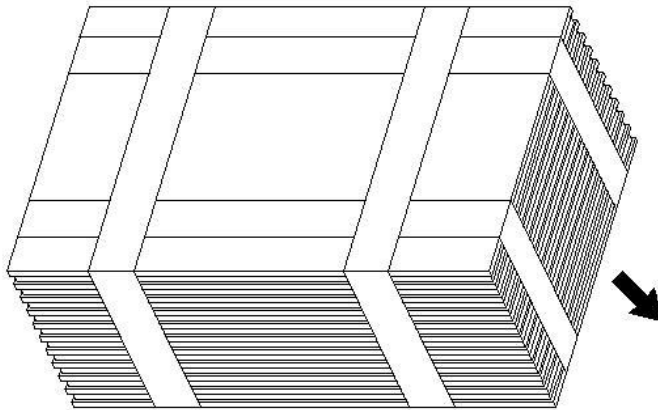

PACKING		
	size (L*W*H) cm	qty (pcs)
inner box	42.5*27.5*1.5	60
outer box	44.5*28.5*36	60*20=1200
gross weight	Kg	
net weight	Kg	

